

规格承认书

SPECIFICATION FOR APPROVAL

客户名称 Customer	B166		
客户料号 Customer No	1950526 UP6001GIN-V1		
产品类别 Product Type	POE电源适配器 POE Power Adaptor		
设计编号 Designed No.	25014	产品型号 Model No.	MP60P-560108-E2
送样日期 Sample Date	2025/10/20	版本 Version	A5
颜色 Colour	<input checked="" type="checkbox"/> 黑色 Black	<input type="checkbox"/> 白色 White	

客户承认签核 CUSTOMER AUTHORIZED SIGNATURE		

PLEASE SIGN AND RETURN ONE COPY 请签字确认并回传本司.

With your signature ,you agree that all contents in this approval sheet are correct and all production units will be manufactured according to the specification described in this sheet.

签字后,您同意本承认书内容,所有产品将按此要求生产.

REMARKS: Please make sure the EMI has been tested with your system/end application and the test result are conformed.

备注:请将我们的产品与配套产品终端连接测 EMI OK 后签字.



东莞市盈正电子有限公司

MITRA POWER SOLUTIONS CO.,LTD

电话(TEL): 0769-83733639

传真 (FAX): 0769-83732069

地址:广东省东莞市横沥镇横沥兴达路23号1号楼101室

Add:Room 101, Building 1, NO.23 Xingda Road, Hengli Town Dongguan Guangdong ,
PEOPLE'S REPUBLIC OF CHINA

<http://www.mitra.cn>

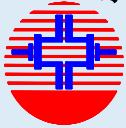

1 HISTORICAL RECORD 变更记录	3
2 DESCRIPTION 概述	
2.1 Power Supply Description 产品概述.....	4
2.2 Power Supply Change Notification 变更事前通知.....	4
2.3 Power Supply Enclosure/housing 电源结构型式.....	4
3 ELECTRICAL CHARACTERISTICS 电气性能	
3.1 AC Input Voltage and Frequency 输入电压及频率.....	4
3.2 Maximum AC Current 最大输入电流.....	4
3.3 Input Inrush Current 最大浪涌(突入)电流.....	4
3.4 No-load Power Consumption 空载功耗.....	4
3.5 Output Voltage 输出电压.....	5
3.6 Output Ripple Voltage 输出纹波电压.....	6
3.7 Time Sequence 时序特性.....	6
3.8 Output Overshoot 输出过冲.....	7
3.9 Output transient response 输出瞬态响应.....	7
3.10 Protection Function 保护功能.....	7
3.11 Efficiency 效率.....	7
4 ENVIRONMENTAL REQUIREMENTS 环境要求	
4.1 Temperature 温度.....	8
4.2 Relative Humidity 相对湿度.....	8
4.3 The Sea Level Altitude 海拔高度.....	8
4.4 Cooling Method 冷却方法.....	8
5 Reliability 可靠性	
5.1 MTBF 平均故障间隔时间.....	8
5.2 Insulation Resistance 绝缘阻抗.....	9
5.3 Hi-Pot 绝缘耐压.....	9
5.4 Leakage Current 漏电流.....	9
5.5 Low Temperature Storage 低温存储.....	9
5.6 High Temperature Storage 高温存储.....	9

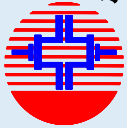

东莞市盈正电子有限公司

Mitra Power solutions Co., Ltd

Specification for Approval

Design No

Customer P/N

25014

6 SAFETY STANDARD 安全标准

6.1	Safety Standard 安规标准	10
6.2	Electromagnetic Compatibility (EMC) 电磁兼容性	10

7 MECHANICAL CHARACTERISTICS 机械性能

7.1	Bending Test 摇摆(弯曲)测试	10
7.2	Tensile Strength Relief Test 拉力测试	10
7.3	Drop Test 跌落测试	11
7.4	Vibration test specifications non-operating with packing 振动测试	11
7.5	Input Connection/country version 输入连接/國別	11
7.6	Unit Weigth 产品单重	11

8 APPENDIX DRAWING 附图

8.1	CIRCUIT DIAGRAM 电路图	12
8.2	PRINT CIRCUIT BOARD LAYOUT 电路板布局图	13
8.3	Overall Drawing 外观图	14
8.4	Nameplate Drawing 铭牌图	15
8.5	Packing Drawing 包装图	16
8.6	instructions 说明书	17

9 SAMPLE TEST REPORT 样品测试报告

9.1	Sample test 样品测试	18
-----	------------------	----

10 IMPORTANT NOTICE 重要提醒 19



东莞市盈正电子有限公司
Mitra Power solutions Co., Ltd

Specification for Approval

Design No

Customer P/N

25014

SPECIFICATION CHANGE RECORD 变更记录

Revision 版本	Change record 变更记录	Confirmed 确认者	Changed date 变更日期
A0	Preliminary Release.	谢杨杨	
A1	Change the appearance diagram; Add AC cable and instruction manual; The nameplate will be provided by the customer instead; Change packaging method/变更外观图;增加AC线和说明书;铭牌改由客户提供;变更包装方式	谢杨杨	2025/5/8
A2	Change 8.3 Overall Drawing/变更 8.3 外观图	梁俊民	2025/8/1
A3	Change 8.3 Overall Drawing,8.4 Nameplate Drawing/变更 8.3 外观图,8.4 铭牌图	梁俊民	2025/8/5
A4	Update the instruction manual for item 8.6/更新8.6项说明书	谢杨杨	2025/9/29
A6	Add customer material number ; Change the appearance of the AC line ; Screw PE bag size change/增加客户料号;变更AC线外观;变更装螺丝PE袋尺寸	谢杨杨	2025/10/20



东莞市盈正电子有限公司

Mitra Power solutions Co., Ltd

Specification for Approval

Design No

Customer P/N

25014

2.1 Power Supply Description 产品概述

This power supply specification is designed for [POE](#) which convert 100Vac ~240Vac to a stabilized DC voltage of [56V](#) with rated output current of [1.08A](#). The POE power adapter is single port, end-span, 1000Mbps data transfer rate.

本通用型以太网供电类电源是将100Vac ~240Vac 输入电压转换成稳定的直流电压 [56V](#)，额定输出电流 [1.08A](#)。该POE电源是单网口输出，采用末端跨接法，信号传输速率为1G。

2.2 Power Supply Change Notification 变更事前通知

The vendor will notify customer for significant design changes, before the implementation. However, process improvements can be an exemption.

有重大设计变动时,在变更实施之前,供应商将通知到客户,工艺改善可以例外。

2.3 Power Supply Frame 电源结构型式

Wall mount 插墙式

Desk-top 桌上式

Open frame 开放式结构/裸板

Other 其它

3.0 ELECTRICAL CHARACTERISTICS 电气性能

3.1 AC Input Voltage and Frequency 输入电压及频率

3.1.1 Rated Input Voltage 额定输入电压：[100-240Vac](#)

3.1.2 Reliable Input Voltage 可输入电压范围：[90-264Vac](#)

3.1.3 Rated Input Frequency 额定输入频率：[50/60Hz](#)

3.1.4 Reliable Input Frequency 可输入频率范围：[47-63Hz](#)

3.2 Maximum Input Current 最大输入电流

Input rated voltage, Output rated load. Input Current [1.5Amps](#) Maximum.

输入额定电压,输出额定负载条件下,最大输入电流为:[1.5Amps](#).

3.3 Input Inrush Current 最大浪涌(突入)电流

Input [100Vac](#) 60Hz, Output rated load(cold start) inrush Current [120Amps](#) peak.

输入[100Vac](#) 60Hz,输出额定负载(冷启动)条件下,最大浪涌(突入)电流为:[120Amps](#).

Input [240Vac](#) 50Hz, Output rated load(cold start) inrush Current [120Amps](#) peak.

输入[240Vac](#) 50Hz,输出额定负载(冷启动)条件下,最大浪涌(突入)电流为:[120Amps](#).

3.4 No-load Loss Power 空载功耗

Input [115/230Vac](#), Output no load. Maximum loss power [0.5Watts](#).

输入[115/230Vac](#),输出空载,最大空载功耗为:[0.5瓦](#).



东莞市盈正电子有限公司

Mitra Power solutions Co., Ltd

Specification for Approval

Design No

Customer P/N

25014

3.5 Output Characteristics 输出特性

Output Voltage 输出电压	Load Output Voltage Range 带载输出电压范围	No load Voltage Range 空载输出电压范围
	52-57VDC	52-57VDC
Output Current 输出电流	Output Minimum Load 输出最小负载	Output Rating Load 输出额定负载
	0A	1.08A
Standard 标准	IEEE 802.3 10BASE-T	
	IEEE 802.3u 100BASE-T	
	IEEE 802.3ab 1000BASE-T	
	IEEE 802.3af	
	IEEE 802.3at	
	IEEE 802.3bt	
Data Transfer Rate 信号传输速率	1000Mbps (Full-duplex)	
Data Pin 数据插脚	1/2, 3/6 & 4/5, 7/8	
POE Type POE 型式	End-span (Type-A) : PIN1/2,3/6	
	End-span (Type-B) : PIN4/5,7/8	
LED Definition 发光二极管定义	LED on 发光二极管亮	Port successfully powered at requested power level 端口在请求的功率级别成功上电
	LED off 发光二极管熄灭	Looking for a valid detection protocol 寻找有效的检测协议



3.6 Output Ripple Voltage 输出纹波电压

3.6.1 The ripple noise voltage test is carried out under ambient 25°C
在环境温度25°C测试输出纹波电压.

3.6.2 Peak to peak ripple is measured with an oscilloscope with a bandwidth of 20MHz.
纹波量测时示波器选用20MHz带宽限制.

3.6.3 Measurement of ripple should parallel a 0.1uF ceramic capacitor and a 47uF electrolytic capacitor at the output of the measuring oscilloscope.
测试时在输出端要并联一颗0.1uF的陶瓷电容和一颗47uF的电解电容.

Input	Output Rated Voltage	Output Current	Output Ripple & Noise
100Vac-240Vac	+56V	1.08A	240mVp-p Max.

3.7 Time Sequence 时序特性

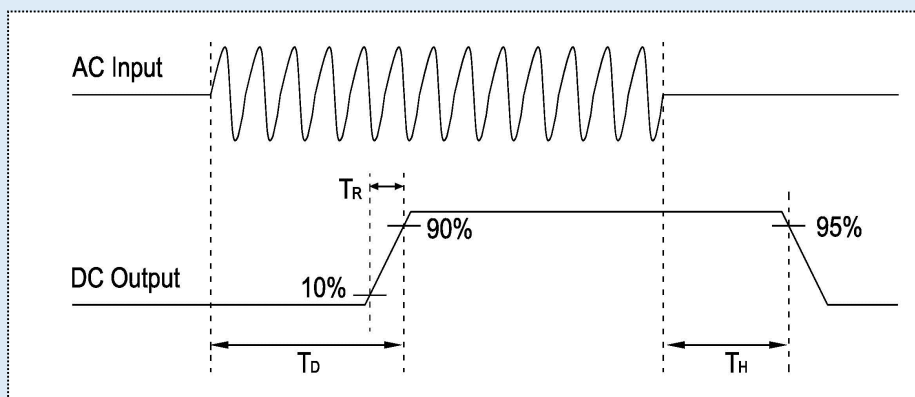

3.7.1 Turn-On Delay Time(T_D) 开机输出延迟时间:

The maximum cold start turn-on delay shall not exceed 3 second at input 100-240Vac and the rated load condition.

在输入100-240Vac,额定负载情况下,最大冷启动打开的延迟不会超出3秒.

3.7.2 Hold-Up Time(T_H) 关机输出维持时间:

The maximum turn-off hold-up time shall be least 5mS at input 100Vac and the rated load condition.

在输入100Vac及额定负载情况下,关机输出维持时间不低于5mS.

The maximum turn-off hold-up time shall be least 10mS at input 240Vac and the rated load condition.

在输入240Vac及额定负载情况下,关机输出维持时间不低于10mS.

3.7.3 Output Rise Time(T_R) 输出上升时间:

Input 100Vac/240Vac and rated load, The rise time shall not exceed 100mS that the output voltage rise from 10% to 90% rated voltage.

在输入100Vac/240Vac,输出额定负载条件下,输出电压由10%额定电压上升至90%额定电压的上升时间不会超过100mS.



东莞市盈正电子有限公司

Mitra Power solutions Co., Ltd

Specification for Approval

Design No

Customer P/N

25014

3.8 Output Overshoot 输出过冲

3.8.1 10% Rated Voltage Max. when the power turn on.

当电源开机时,过冲电压值最大为额定电压值的10%.

3.8.2 10% Rated Voltage Max. when the power turn off.

当电源关机时,过冲电压值最大为额定电压值的10%.

Output Rated Voltage	Overshoot Voltage(V)	
	Turn on	Turn off
+56V	10%	10%

3.9 Output transient response 输出瞬态响应

Output Voltage Tolerance Limited	Rate Slew	Load change
		负载变化
56Vdc±10%	0.25A/μs	20% to 80% Load

Transient response measurements shall be made with a load changing repetition rate of 100Hz to 10kHz.

测量瞬态响应与负载改变的频率应在100Hz至10kHz.

3.10 Protection Function 保护功能

3.10.1 Over Voltage Protection 过压保护

The power supply shall protect itself from any over voltage condition.

电源在过压情况下可自动保护。

3.10.2 Over Current Protection 过流保护

In the input voltage 115/230Vac, The power supply shall protect itself from any over current condition.it can be automatically restored to be normal when the overcurrent condition removed.

在 115/230Vac输入时 , 电源在过流情况下可自动保护,当过流情况解除后,可自动恢复正常。

3.10.3 Short Circuit Protection 短路保护

Shorting of output will not cause power supply to damage, or any safety hazard.

The power supply shall resume normal operation after the short is removed.

输出短路时电源不会损坏,不会有任何的安全危险,短路解除后电源恢复正常工作。

3.10.4 Input Protection 输入保护

The power supply has a current fuse to protect itself.

该电源由一颗电流保险丝来达到输入保护。

3.11 Efficiency 效率

Input 115/230Vac. and 100%,75%,50%,25% Rated Load condition. Average efficiency (η):87% Min.

在输入115/230Vac,输出100%,75%,50%,25%额定负载,平均效率 (η): 87% Min.

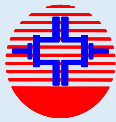

东莞市盈正电子有限公司

Mitra Power solutions Co., Ltd

Specification for Approval

Design No

Customer P/N

25014

4.0 ENVIRONMENTAL REQUIREMENTS 环境要求

4.1 Temperature 温度

4.1.1 Storage temperature (Non-operating) 可存储温度(非操作状态):

-10 to 70 degrees C [-10] 至 [70]摄氏度.

Typical values:25 degrees C. 典型值:25摄氏度.

4.1.2 Operating temperature Limits 可操作温度:

0 to 40 degrees C. [0] 至 [40]摄氏度.

Typical values:25 degrees C. 典型值:25摄氏度.

4.2 Relative Humidity 相对湿度

4.2.1 Storage Humidity (Non-operating) 存储湿度(非操作状态):

5% to 90% RH (Non-condensing) [5%] 至 [90%],无凝水状态.

4.2.2 Operating Humidity Limits 操作湿度:

5% to 90% RH (Non-condensing) [5%] 至 [90%],无凝水状态.

4.3 The Sea Level Altitude 海拔高度

4.3.1 Storage Altitude 可存储海拔度(非操作状态):

0 to +2,000m above the sea level [0] 至 [2,000]米.

4.3.2 Operating Altitude 可工作海拔度:

0 to +2,000m above the sea level [0] 至 [2,000]米.

4.4 Cooling Method 冷却方法

Natural air convection 自然冷却

5.0 Reliability 可靠性

5.1 MTBF: Mean Time Between Failure 平均故障间隔时间

The power supply shall be designed and manufactured to have more than50,000 operating hours (about 5.7 years for 24-hour-operation a day) of mean time between failure (MTBF) at 90% of confidence level while operating under the prevailing conditions below 0.1% Average field failure rate @ 25°C.

在如下条件,该电源设计和制造平均故障间隔时间(MTBF)将超过50,000个操作时间(大约操作24小时/每天/5.7年),信心指数为90%,平均现场故障率0.1%。

Input Voltage: 115/230Vac

输入电压: 115/230Vac

Output Load: of Rated load

输出负载: 额定负载条件

Ambient Temperature: at 25 degrees C Room Temperature

环境温度: 室温25摄氏度

Standard 标准 : MIL-STD-HDBK-217

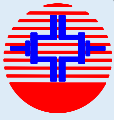

东莞市盈正电子有限公司

Mitra Power solutions Co., Ltd

Specification for Approval

Design No

Customer P/N

25014

5.2 Insulation Resistance 绝缘阻抗

Test Points	检测部位	Condition & Specification 条件及规格
Input to Output	输入-输出	500Vdc 100MΩ min. (at ambient temperature 25 degree C, humidity 90%) 500Vdc 100MΩ 最小. (在室温25摄氏度,湿度90%条件下).
Input to Case	输入- 外壳	500Vdc 100MΩ min. (at ambient temperature 25 degree C, humidity 90%) 500Vdc 100MΩ 最小. (在室温25摄氏度,湿度90%条件下).
Output To Case	输出 - 外壳	Non Isolated

5.3 Hi-Pot 绝缘耐压

Test Points	检测部位	Condition & Specification 条件及规格
Input to Output	输入-输出	3000Vac 50Hz, 60S, ≤5mA.
Input to Case	输入- 外壳	3000Vac 50Hz, 60S, ≤5mA.
Output to Case	输出- 外壳	Non Isolated

When the voltage of 3KVac is applied, and the voltage applied to the insulation under test is gradually raised from zero to the prescribed voltage in 0.1s, and held at that value for 60s between the input and output and between the input and housing, the current sensitivity shall be less than 5mA. After this test, the adapter shall exhibit no electrical and mechanical abnormalities. (voltage of 3.75KVac, 2s and sensitivity current 5mA shall be applied to the product line).
在输入端对输出端及输入端对外壳间施加了3KVac电压,并且测试中施加在绝缘上的电压是在0.1s内由0V逐渐上升到规定值,然后保持60S,电流灵敏度设置在5mA。经过以上测试,电源应不发生电气及机械上的异常。(注:在生产线上批量生产时以3.75KVac, 2s 5mA进行测试)。

5.4 Leakage Current 漏电流

The leakage current shall not exceed 0.25mA for CLASS II when power supply is operated maximum input voltage and maximum load.

当电源供应器操作在最大输入及最大负载情况下,其漏电流应小于0.25mA,满足CLASS II等级。

5.5 Low Temperature Storage 低温存储

Keep the parts unpacked without connecting to the power for 96 hours at -10°C. Electrical character tested and appearance after resuming 1 hours at room temperature. The electrical performance and appearance should be normal.

产品不包装,不通电。在-10°C条件下保存96小时,常温恢复1小时后,进行外观、电气性能检测。产品电气性能及外观应是正常的。

5.6 High Temperature Storage 高温存储

Keep the parts unpacked without connecting to the power for 96 hours at 70°C. Electrical character tested and appearance after resuming 1 hours at room temperature. The electrical performance and appearance should be normal.

产品不包装,不通电。在70°C条件下保存96小时,常温恢复1小时后,进行外观、电气性能检测。产品电气性能及外观应是正常的。

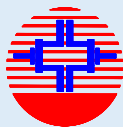

东莞市盈正电子有限公司

Mitra Power solutions Co., Ltd

Specification for Approval

Design No

Customer P/N

25014

6.0 STANDARD 标准

6.1 SAFETY STANDARD 安全标准

* Meet [ETL62368-1/EN62368-1](#)

6.2 ELECTROMAGNETIC COMPATIBILITY (EMC) 电磁兼容性

6.2.1 EMI 电磁干扰

This power supply shall compliance with the following Criterion 本电源将遵照以下标准:

6.2.1.1 Conduction Emission 传导干扰度

* [FCC PART 15B/EN 55032/EN 55035](#)

6.2.1.2 Radiated Emission 辐射干扰度

* [FCC PART 15B/EN 55032/EN 55035](#)

6.2.2.1 ESD 静电抗扰度

Standard: * [EN61000-4-2](#)

AIR DISCHARGE at [±8KV](#), CONTACT DISCHARGE at [±4KV](#).

6.2.2.2 Surge 雷击浪涌

differential mode: [1KV](#)

common mode: [2KV](#)

The common mode must test with end application. 共模雷击搭配客户产品测试.

Remarks: EMC-SPECIFICATION test with the Pure resistance as load to test,and we only responsible for the product we supplied.

电磁兼容性测试是以纯电阻作为负载测试的，我们只对单品测试负责。

7.0 MECHANICAL CHARACTERISTICS 机械性能

7.1 Bending Test 摇摆(弯曲)测试

Test the metallurgical equipment with fixed plug,handing weight is [300g](#),

[±60](#) degrees from side to side, swing [45](#) times per minute, swing more than [1000](#) times
(Remark: ±60 degrees, that is to say 120 degrees for a cycle,counting 1 times)

以测试冶具固定Plug,吊重[300g](#),左右摇摆[±60](#)度,每分钟摇摆[45](#)次，摇摆[1000](#)次以上(注:±60度即120度为一个循环,算1次)

7.2 Tensile Strength Test 拉力测试

put the weight of [4 kg](#) on SR for [1](#) minute, SR should not shift or damage.

put the weight of [7 kg](#) on DC Cable after [1](#) minute,inner core shall not break .

在DC线的SR卡上施以[4Kg](#)之重量[1](#)分钟，产品无短路，无开路，围卡无松脱。

在DC线线体上施以[7Kg](#)之重量[1](#)分钟后，检查内芯不可有拉断现象。



东莞市盈正电子有限公司

Mitra Power solutions Co., Ltd

Specification for Approval

Design No

Customer P/N

25014

7.3 Drop Test 跌落测试

The adapter shall exhibit no abnormality in mechanical or electrical performance when it is dropped 6 times to hardwood(20mm thickness) from a height of 0.75m, with each of the 6 different sides of the adapter 1 times. The electrical and mechanical performance should be normal after the tested. Small nicks or slight deformations in the corners of the housing, or cracks not penetrating the inside may be accepted. (at:25°C±5°C).

适配器经过落地测试后应无机械或电气性能异常,从 0.75m 垂直高度自由跌落到20mm厚度的硬木质板上(硬木质板应放置于水泥基座或同等无弹性的地面上),共跌落6次,6个不同面各1次. 测试后产品电气和机械功能正常,外观或角落有轻微的变形或出现不穿透裂纹是可以接受的(在25°C±5°C)。

7.4 Vibration test specifications non-operating with packing 振动测试(未运行,带包装)

10Hz to 55Hz with sweep at a breadth 2.0mm for 20 Minutes for each of the perpendicular axes X,Y,Z. After the test the electrical performance shall be normal.

振动频率: 10Hz-50Hz; 振幅:2mm; X、Y、Z三个方向各20分钟; 振动测试后产品电气性能应是正常的。

7.5 Input Connection/country version 输入连接/國別 :

7.7.1.1 Wall plug or Cord to Cord Type 插墙式或导线式

- For European/欧规, For US 3PIN/美规, For China/中规, For Japanese/日规, For UK 3PIN/英规, For Korea/韩规, For Argentina/阿根廷, For Australia/澳规, For US/美规, For Brazil/巴西规, For Singapora/新加坡, ROC (Taiwan) /台湾规

7.5.1.2 Desktop Socket and Terminal Type 桌上型母座或端子式

- 2PIN Socket, 3PIN Socket, Terminal type

7.6 Unit Weight 产品单重

The weight of the unit power supply shall be about 166 g(Ref).

产品单重大约: 166 克 (供参考).

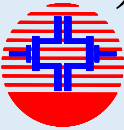
 东莞市盈正电子有限公司 Mitra Power solutions Co., Ltd	Specification for Approval	
	Design No	Customer P/N
	25014	

8.1 CIRCUIT DIAGRAM 电路图(供参考)

 东莞市盈正电子有限公司 Mitra Power solutions Co., Ltd	Specification for Approval	
	Design No	Customer P/N
	25014	

8.2 Screen printing figure 丝印图(供参考)

TOP OVERLAY

BOTTOM OVERLAY

BOTTOM LAYER

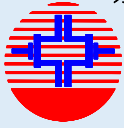

东莞市盈正电子有限公司
Mitra Power solutions Co., Ltd

Specification for Approval

Design No

Customer P/N

25014

8.3 Overall Drawing 外观图

外壳(Enclosure): BLACK(LEAD FREE) 外壳 : 黑色

外壳尺寸(The power supply size): L:111.3*W:47*H:31.6mm

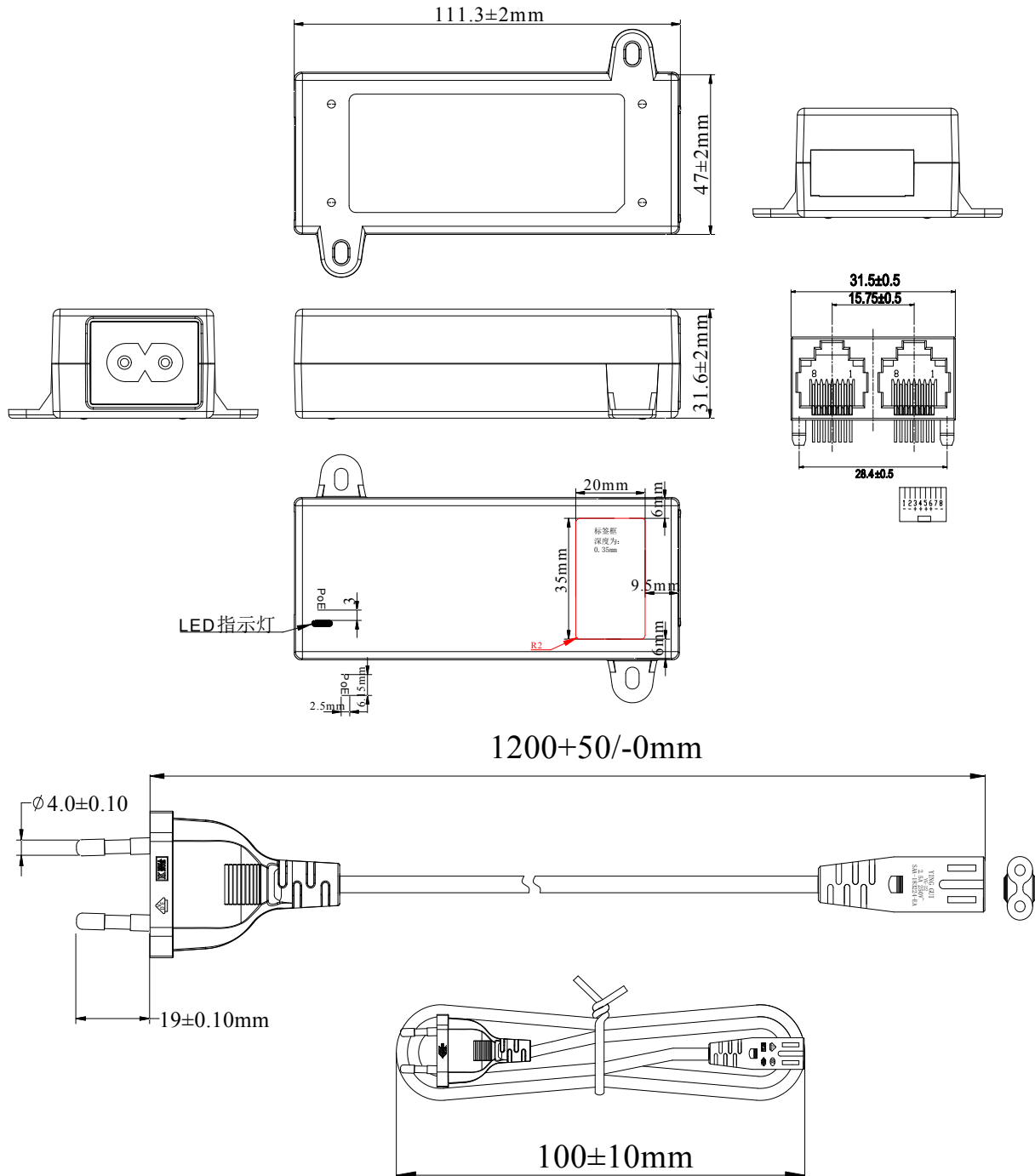

AC线规格 (AC CABLE SPEC) :

H03VVH2-F 0.75mm²x2C 1.2M 黑色 (BLACK) 欧规插头+C8

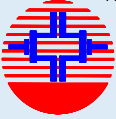
 东莞市盈正电子有限公司 Mitra Power solutions Co., Ltd	Specification for Approval	
	Design No	Customer P/N
	25014	

8.4 Nameplate Drawing 铭牌图

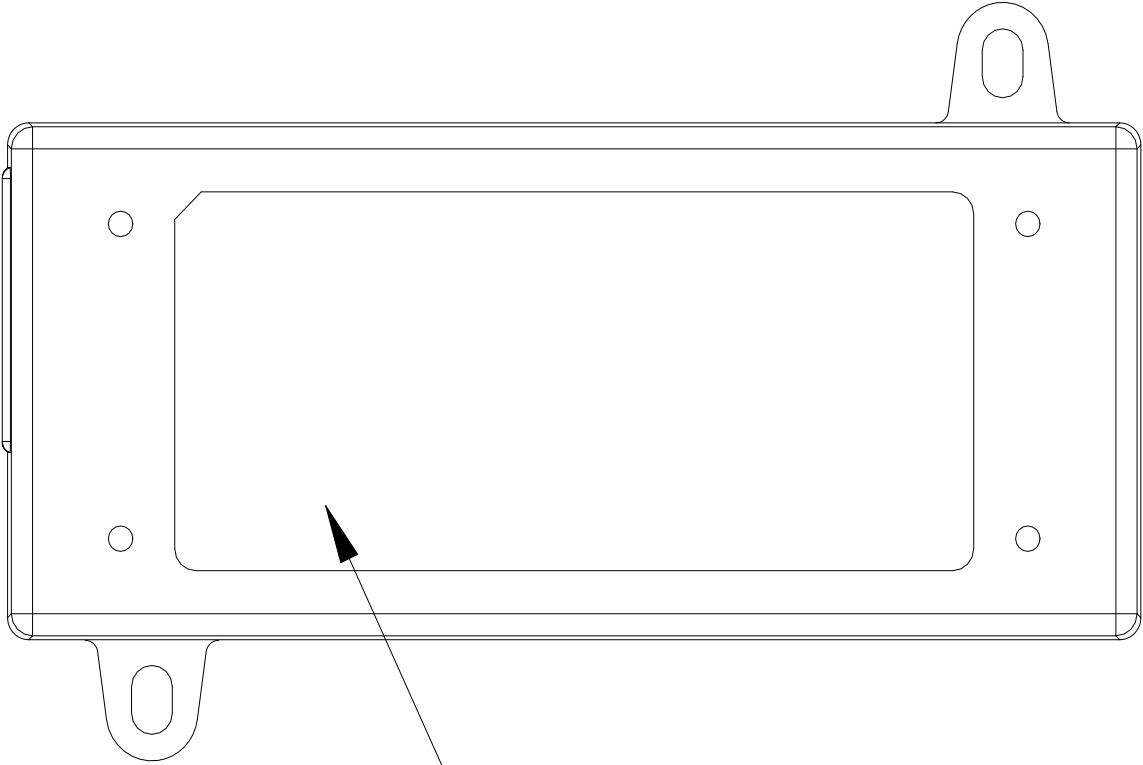

铭牌由客户提供

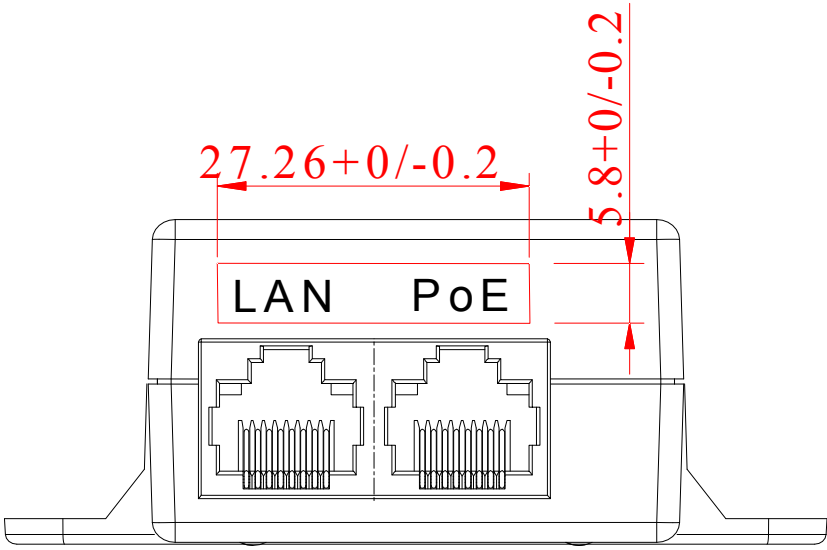

注：“LAN PoE”字体高度为3.5mm

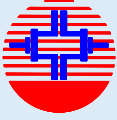
 东莞市盈正电子有限公司 Mitra Power solutions Co., Ltd	Specification for Approval	
	Design No	Customer P/N
	25014	

8.5 Packing Drawing 包装图

外箱：B=B

平卡：B33

牛皮盒：400G牛皮纸

(4*5) *3 layers, total=60PCS

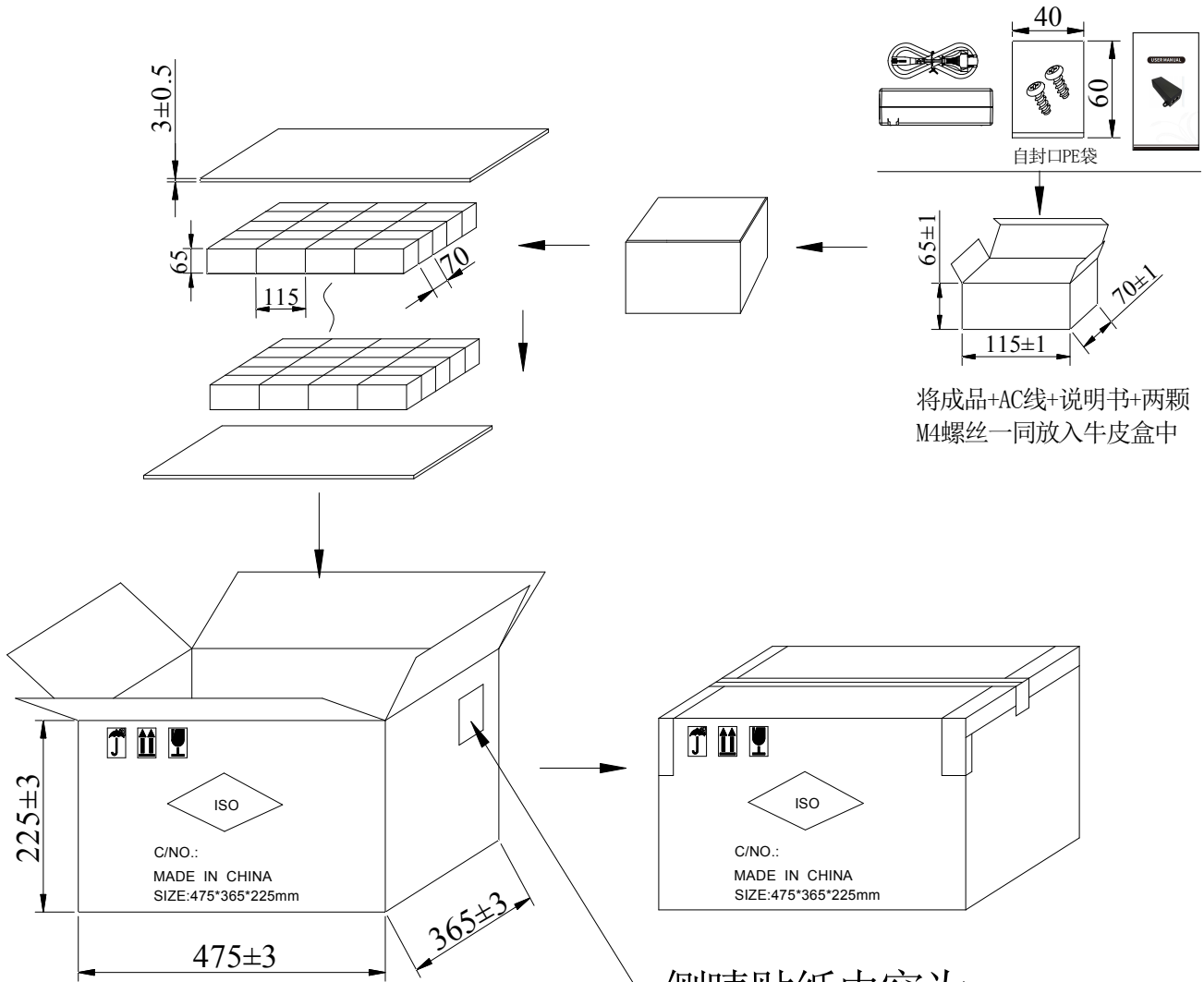

正唛印刷内容为:

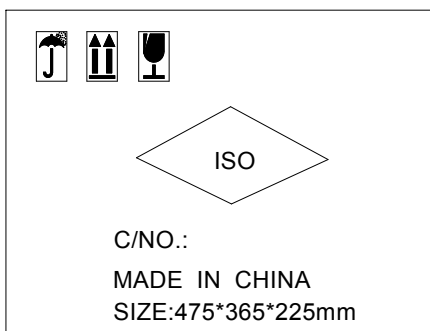

侧唛贴纸内容为:





东莞市盈正电子有限公司
Mitra Power solutions Co., Ltd

Specification for Approval

Design No

Customer P/N

25014

8.6 instructions 说明书

折好成品尺寸：L100*W60mm 105g书纸 单色双面印刷

USER MANUAL



Product Overview

The MP60P-560108-E2 PoE Injector fully complies with af/at/bt standard, and can work with all af/at/bt PoE compliant PD (Powered Devices) or PoE Receiver Adapters or other equivalent product, to expand your network to where there are no power line or outlet, where you wish to fix device such as AP, IP Camera or IP Phone, etc.

Product Features

- Complies with af/at/bt Standard;
- Use 4 pairs of power supply, and output power more;
- Auto detect power device;
- Support PoE power up to 60W;
- Remote power and Data feeding up to 100m;
- Gigabit Internet port;
- Built in Power, Plug-and-play, requires no configuration;
- Intelligent protection and power supply;
- Working temperature: 0 °C to 40 °C;
- Short Circuit Protection;
- Elegant plastic shell design;

封面

Product Specifications

Model	MP60P-560108-E2
Port	OUT: 1x10/100/1000Mbps RJ45 Port IN: 1x10/100/1000Mbps RJ45 Port
PoE Standard	IEEE802.3af/at/bt
Network Media(Cable)	10BASE-T: UTP category 3, 5 cable (≤100m) 100BASE-TX: UTP category 5, 5e cable (≤100m) 1000BASE-T: UTP category 5e, 6 cable(≤100m)
LED Indicator	POWER(Green), ACTIVE(Green)
PSE Power on RJ-45	Data Pairs 1/2(-), 3/6(+) Data Pairs 4/5(+), 7/8(-)
PoE Power Output	60W Max
Input Voltage	AC 100-240V 50/60Hz
Dimensions (L*W*H)	111.3*47.0*31.6mm
Installation	Desktop
Operation Temperature	0°C~40°C
Storage Temperature	-10°C~70°C
Operation Humidity	5%~90% RH non-condensing
Storage Humidity	5%~90% RH non-condensing
Surge Protection	Differential mode ±1KV, Common mode ±2KV
Electrostatic Standard	Contact ±4KV, Air ±8KV
MTBF	>50000 hours

Ordering information

Model	product information
MP60P-560108-E2	60W PoE Injector

封底

 东莞市盈正电子有限公司 Mitra Power solutions Co., Ltd	Specification for Approval	
	Design No	Customer P/N
	25014	

9.1 Sample test 样品测试

 东莞市盈正电子有限公司 Mitra Power solutions Co., Ltd	Specification for Approval	
	Design No	Customer P/N
	25014	

10 IMPORTANT NOTICE 重要提醒

Reminder: According to the new Low Voltage directive 2014/35/EU requirements, there must have manufacturer's and importer's information on the end application products or on product packaging or the documentation, the information is mean for: company name and address or trademark logo and registered trade name or postal address, the address should be a single location, otherwise, if anything happened, we will not take responsibility for it.

特别提醒客户：根据新版低压指令2014/35/EU要求，客户必须在产品上或产品包装、或者产品附带的文档中显示制造商和进口商名称、注册的商标名称或商标标志和邮政地址，地址应当是单一地点。如因此造成的相关损失，本公司不承担任何责任和风险。